

3 step switch MTS

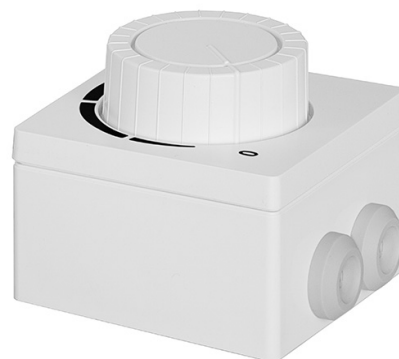
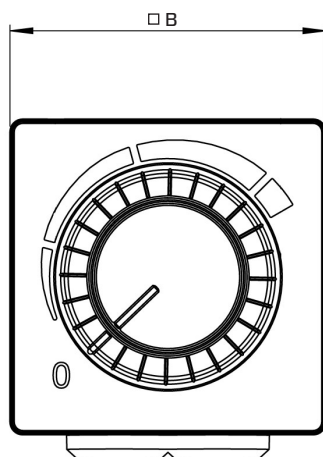
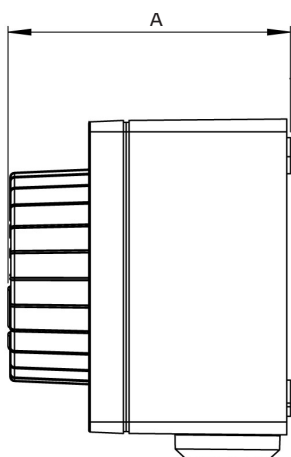

Type	ID	A mm	B mm	C mm	D mm	Weight kg
MTS 10	128145	74	83	66,5	66,5	0,2

- 3 step switch MTS
- Surface and flush mounting
- Max. ambient temp 50 °C
- VDE
- Protection class IP 44

CE	U _{max.}	250V~	I _{max.}	50Hz	4A
	RU	120V~	60Hz	P _{max.}	1hp
		240V~	60Hz		2hp

Wiring diagram :

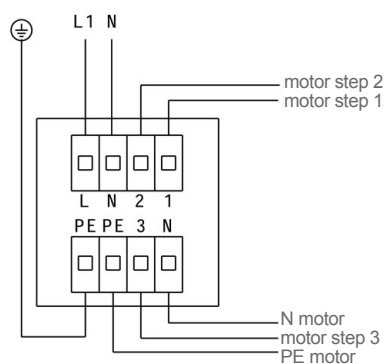

Assembly :

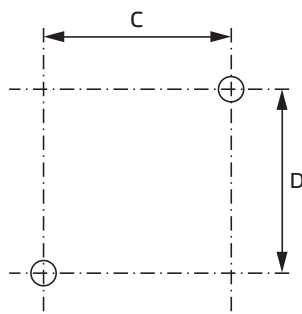

Legend

- I_{max.} = Max. operating current
- U_{max.} = Maximum voltage
- P_{max.} = Maximum power